



Hi3516E V100 Professional HD IP Camera SoC

## **Brief Data Sheet**

**Issue**            **01**

**Date**             **2017-06-07**

**Copyright © HiSilicon Technologies Co., Ltd. 2016-2017. All rights reserved.**

No part of this document may be reproduced or transmitted in any form or by any means without prior written consent of HiSilicon Technologies Co., Ltd.

### **Trademarks and Permissions**



**HISILICON**, and other HiSilicon icons are trademarks of HiSilicon Technologies Co., Ltd.

All other trademarks and trade names mentioned in this document are the property of their respective holders.

### **Notice**

The purchased products, services and features are stipulated by the contract made between HiSilicon and the customer. All or part of the products, services and features described in this document may not be within the purchase scope or the usage scope. Unless otherwise specified in the contract, all statements, information, and recommendations in this document are provided "AS IS" without warranties, guarantees or representations of any kind, either express or implied.

The information in this document is subject to change without notice. Every effort has been made in the preparation of this document to ensure accuracy of the contents, but all statements, information, and recommendations in this document do not constitute a warranty of any kind, express or implied.

## **HiSilicon Technologies Co., Ltd.**

Address: Huawei Industrial Base  
Bantian, Longgang  
Shenzhen 518129  
People's Republic of China

Website: <http://www.hisilicon.com>

Email: [support@hisilicon.com](mailto:support@hisilicon.com)



# Hi3516E V100 Professional HD IP Camera SoC Brief Data Sheet

## Key Specifications

### Processor Core

ARM926@800 MHz with 32 KB I-cache and 32 KB D-cache

### Video Encoding

- H.264 BP/MP/HP
- H.265 Main Profile
- MJPEG/JPEG baseline

### Video Encoding Performance

- Maximum resolution of 1536 x 1536 for H.264/H.265 encoding, and maximum width of 2048
- Real-time multi-stream H.264/H.265 encoding capabilities
  - 1920 x 1080@20 fps+720 x 576@20 fps
- JPEG snapshot at 2 megapixels@5 fps
- CBR, VBR, FIXQP, AVBR, and QPMAP modes
- Maximum 30 Mbit/s output bit rate
- Encoding of eight ROIs

### Intelligent Video Analysis

Integrated IVE, supporting various intelligent analysis applications such as motion detection, perimeter defense, and video diagnosis

### Video and Graphics Processing

- 3DNR, image enhancement, and DCI
- Anti-flicker for output videos and graphics
- 1/15x to 16x video and graphic scaling
- Overlaying of video and graphics
- Picture rotation by 90°, 180° or 270°
- Picture mirroring and flipping
- OSD overlaying of eight regions before encoding

### ISP

- 3A (AE, AF, and AWB) function. The third-party 3A algorithms are supported.
- FPN removal and DPC
- LSC, LDC, and purple edge correction
- Direction-adaptive demosaic
- Gamma correction, DCI, and color management and enhancement
- Adaptive region de-fog
- Multi-level NR (BayerNR and 3DNR) and sharpening enhancement
- Local tone mapping
- Sensor built-in WDR
- DIS
- ISP tuning tools for the PC

### Audio Encoding/Decoding

- Voice encoding/decoding complying with multiple protocols by using software
- Compliance with the G.711, G.726, and ADPCM protocols
- Audio 3A functions (AEC, ANR, and AGC)

### Security Engine

- Various encryption and decryption algorithms

implemented by using hardware, including AES, DES, 3DES, and RSA

- HASH (SHA1/SHA256/HMAC\_SHA/HMAC\_SHA256) algorithms implemented by using hardware
- Integrated 512-bit one-time program only and random number generator

### Video Interfaces

- VI interfaces
  - 8-/10-/12-/14-bit RGB Bayer DC timing VI
  - BT.601, BT.656, and BT.1120 VI interfaces
  - MIPI, LVDS/sub-LVDS, and HiSPi
  - Compatibility with mainstream HD CMOS sensors provided by Sony, ON, OmniVision, and Panasonic
  - Compatibility with the electrical specifications of parallel and differential interfaces of various sensors
  - Programmable sensor clock output
  - Maximum input resolution of 2048 x 2048, up to 250 megapixels/s
- VO interfaces
  - One BT.656 VO interface
  - 6-bit RGB565 serial LCD output

### Audio Interfaces

- Integrated audio CODEC supporting 16-bit audio inputs and outputs
- Mono-channel differential MIC inputs for reducing the background noises
- Single-ended dual-channel input
- I<sup>2</sup>S interface for connecting to the external audio CODEC

### Peripheral Interfaces

- POR
- One integrated high-precision RTC
- Integrated 3-channel LSADC
- Three UART interfaces (including one 4-wire interface)
- IR, I<sup>2</sup>C, SPI, and GPIO interfaces
- Four PWM interfaces
- Three SDIO 2.0 interfaces, two interfaces support the 3.3 V level and 1.8 V level
- One USB 2.0 host/device port
- RMII in 10/100 Mbit/s full-duplex or half-duplex mode, TSO network acceleration, and PHY clock output

### External Memory Interfaces

- SDRAM interface
  - Embedded 512 Mb DDR
- SPI NOR flash interface
  - 1-/2-/4-wire mode
  - Maximum capacity of 32 MB
- SPI NAND flash interface with maximum 4 Gbits capacity
- eMMC 4.5 interface with 4-bit data width

### Boot

- Booting from the SPI NOR flash, SPI NAND flash, or eMMC
- Secure boot

**Hi3516E V100 Professional HD IP Camera SoC Brief Data Sheet****SDK**

- Linux-3.18-based SDK
- High-performance H.264 PC decoding library
- High-performance H.265 PC/Android/iOS decoding library

**Physical Specifications**

- Power consumption
  - 1080p20, typical power consumption of 600 mW
  - Deep standby wakeup
- Operating voltages
  - 0.9 V core voltage
  - 3.3 V±10% I/O voltage
  - 1.8 V for SDRAM interface voltage
- Package
  - Body size of 10 mm x 14 mm (0.39 in. x 0.55 in.), 0.65 mm (0.03 in.) ball pitch, TFBGA RoHS package with 231 pins

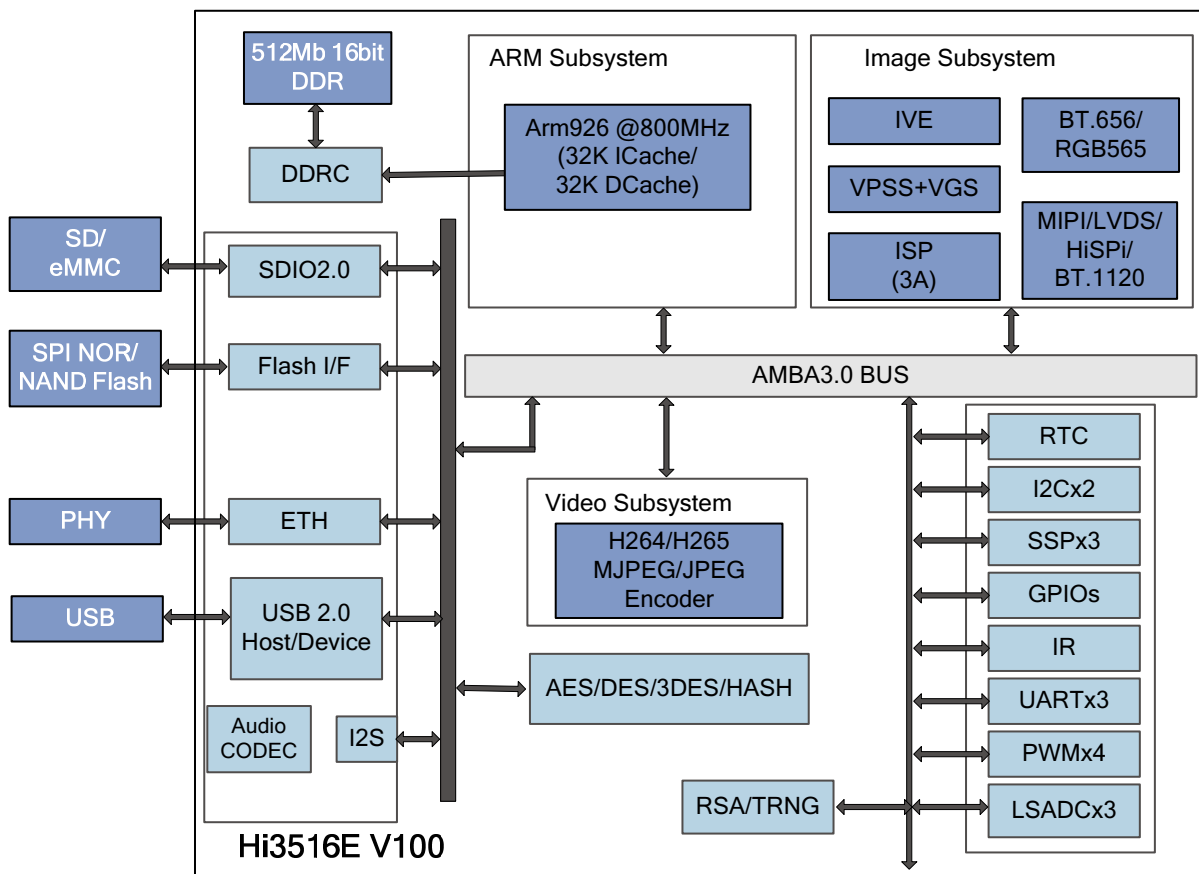
**Functional Block Diagram**

Hi3516E V100 is a new-generation SoC designed for the industry-dedicated HD IP camera. It has an integrated new-generation ISP and the latest H.265 video compression encoder in the industry. It uses the advanced low-power technology and architecture design. All of these features enable Hi3516E V100 to lead the industry in the low bit rate, high profile, and low power consumption. Hi3516E V100 integrates the POR, RTC, audio CODEC, and standby wakeup circuit, which significantly reduces customers' EBOM cost. In addition, the interface design similar to that of other HiSilicon DVR and NVR chips facilitate development and mass production of customer's products.



# Hi3516E V100 Professional HD IP Camera SoC Brief Data Sheet

## Hi3516E V100 HD IP Camera Solution

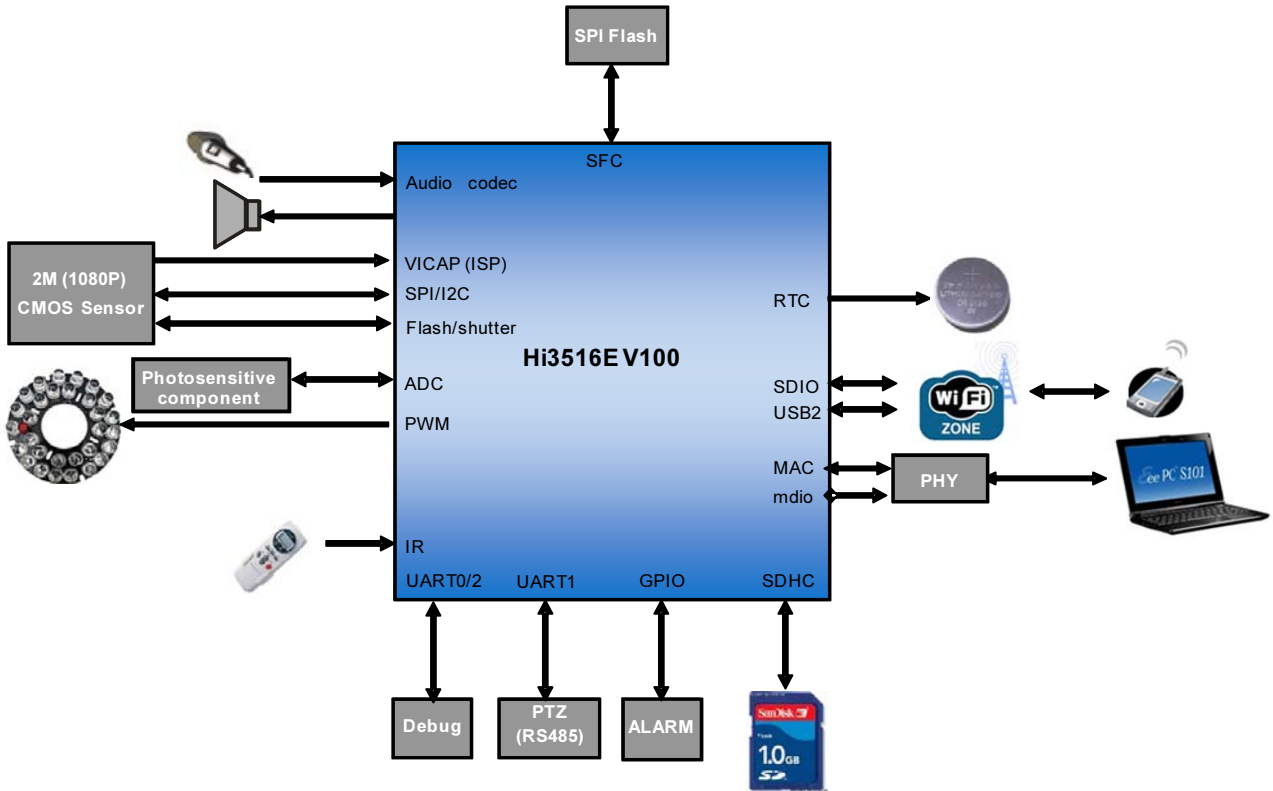



## Acronyms and Abbreviations

3DES	Triple Data Encryption Standard
ADPCM	adaptive differential pulse code modulation
AE	automatic exposure
AEC	acoustic echo cancellation
AES	Advanced Encryption Standard
AF	automatic focus
ALC	automatic level control
ANR	audio noise reduction
AVBR	adaptive variable bit rate
AWB	automatic white balance
CBR	constant bit rate
CMOS	complementary metal-oxide-semiconductor
CODEC	coder/decoder
DC	direct current
DCI	dynamic contrast improvement
DDR	double data rate
DES	Data Encryption Standard
DIS	digital image stabilization
DNR	digital noise reduction
DPC	defect pixel correction
DVR	digital video recorder
EBOM	engineering bill of materials
eMMC	embedded multimedia card
FPN	fixed pattern noise
GPIO	general-purpose input/output
HD	high definition
HiSPi	high-speed serial pixel interface
I <sup>2</sup> C	inter-integrated circuit
I <sup>2</sup> S	inter-IC sound
IR	infrared

**Hi3516E V100 Professional HD IP Camera SoC Brief Data Sheet**

ISP	image signal processor
IVE	intelligent video engine
LCD	liquid crystal display
LDC	lens distortion correction
LSC	lens shading correction
LVDS	low voltage differential signal
MIC	microphone
MIPI	mobile industry processor interface
NR	noise reduction
NTSC	National Television System Committee
NVR	network video recorder
OSD	on-screen display
OTP	one-time programmable
PAL	phase alternating line
POR	power-on reset
PWM	pulse-width modulation
RMII	reduced media independent interface
RoHS	Restriction of Hazardous Substances
ROI	region of interest
RSA	Rivest-Shamir-Adleman
RTC	real-time clock
SAR ADC	successive approximation register analog-to-digital converter
SDHC	Secure Digital High Capacity
SDIO	secure digital input/output
SDK	software development kit
SDRAM	synchronous dynamic random access memory
SoC	system-on-chip
SPI	serial peripheral interface
TFBGA	thin & fine ball grid array
TSO	TCP segmentation offload
UART	universal asynchronous receiver transmitter
VBR	variable bit rate



**Hi3516E V100 Professional HD IP Camera SoC Brief Data Sheet**

VGA	video graphics array
VI	video input
VO	video output
WDR	wide dynamic range